

# 12 – 15 GHz VOLTAGE TUNED OSCILLATOR

VTO-13500-22M

## Overview:

Phase Matrix's VTO-13500-22M is a low-noise fundamental voltage-controlled source, which covers 12 to 15 GHz and can be used as a clock in high-speed systems or as a local oscillator or transmitter oscillator in high-frequency communications and radar systems. This low-noise source uses a high-performance, low-noise silicon bi-polar junction transistor (Si BJT) in conjunction with a hyper-abrupt varactor diode to tune over 3 GHz of frequency range in Ku-band. A GaAs MMIC buffer amplifier is used to provide the necessary power output and load isolation of the oscillators.

## Features:

- Operating frequency 12 to 15 GHz
- Output power 10 dBm min.
- Phase noise < -90 dBc/Hc @ 100 kHz
- Low power consumption
- Modulation sensitivity 100 to 250 MHz/V
- Tuning voltage 0 to 20 V

## Applications:

- Low-noise X-band source
- Radars/Communications



## Specifications

### ABSOLUTE MAXIMUM RATINGS

PARAMETER	UNITS	RATING
Positive Supply Voltage	V	+6
Negative Supply Voltage	V	-12
Tuning Voltage	V	0 to +20
Operating Temperature	C	-10° to +85°
Storage Temperature	C	-40° to +125°

### ELECTRICAL SPECIFICATIONS (measured at 0° to +70°)

PARAMETER	UNITS	MIN.	TYP.	MAX.
Center Frequency $f_0$	GHz	12		15
Vt @ 12 GHz	V	0		
Vt @ 15 GHz	V			20

### ELECTRICAL SPECIFICATIONS (continued)

PARAMETER	UNITS	MIN.	TYP.	MAX.
Output Power (50 ohms load)	dBm	10	12	16
Tuning Sensitivity	MHz/V	100		250
Tuning Sensitivity Ratio			2:1	
Modulation Bandwidth	MHz	20		
Output Return Loss	dB	10	12	
Second Harmonic (below carrier)	dBc			-20
Third Harmonic (below carrier)	dBc			-20
Spurious Output (below carrier)	dBc			-60
Phase Noise @ 100 kHz from $f_0$	dBc/Hz		-90	-85
Phase Noise @ 10 MHz from $f_0$	dBc/Hz			-125
Freq. Drift over Temp.	MHz			100

# 12 – 15 GHz VOLTAGE TUNED OSCILLATOR

Model VTO-13500-22M

Specifications and ordering information subject to change without notice.

## Specifications (continued)

### ELECTRICAL SPECIFICATIONS (continued)

PARAMETER	UNITS	MIN.	TYP.	MAX.
Pulling Figure (12 dB Return Loss)	MHz		10	
Pushing Figure ( $\pm 25$ V)	MHz		50	
Positive Supply Voltage	V	+4.85	+5	+5.15
Positive Supply Current	mA		75	85
Negative Supply Voltage	V	-9.7	-10	-10.3
Negative Supply Current	mA		20	25

## Packaging Information

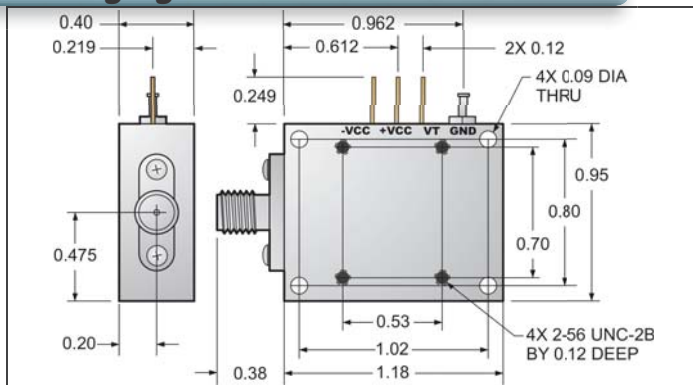

M = Connectorized

## Ordering Information

### ORDERING INFORMATION

DESCRIPTION	SPECIFICATION
Model No.	VTO-13500-22
Packaging Options	M

#### Notes:

- 1) See our [catalog](#) for information about other microwave components and sub-assemblies.

Data sheet PN: DS\_VTO-13500-22 Rev. 2

Copyright © 2009 Phase Matrix, Inc. All rights reserved.

Phase Matrix, Inc. ○ 109 Bonaventura Drive, San Jose CA 95134 ○ Tel: 1-408-428-1000 ○ [www.phasematrix.com](http://www.phasematrix.com)