

# THE DOWN CONVERTER – A CRITICAL SYNTHETIC INSTRUMENT TECHNOLOGY

**Charanbir Mahal, VP Engineering  
Phase Matrix, Inc.  
109 Bonaventura Dr.  
San Jose, CA 95134-2106  
(408)-428-1000  
cmahal@phasematrix.com**

**Michael N. Granieri, Ph.D.  
Phase Matrix, Inc.  
109 Bonaventura Dr.  
San Jose, Ca 95134-2106  
703-644-6015  
mgranieri@phasematrix.com**

**Abstract - This paper provides a brief overview of RF/Microwave frequency translation functionality (Up Converters & Down Converters) and technology and discusses why they are important in the context of DOD related Test and Measurement. The paper then briefly reviews the concept of Synthetic Instruments (SI) and the role of the Down Converter in the SI paradigm. The paper then introduces the reader to some critical Down Converter specifications that must be optimized over a broad array of user RF/Microwave test requirements. Based on this dissertation, the authors set forth their “One size does not fit all” thesis and introduce the concept of a “Family of Down Converters”. The authors then describe a flexible/modular Down Converter Architecture that can be tailored to address a broad cross-section of Down Converter user needs. The paper then concludes with a summary statement by the authors about this critical Synthetic Instrument technology.**

## **INTRODUCTION**

One of the most critical technologies employed by the RF/Microwave designer is the RF/MW Frequency Translation Device (FTD), or converter. These devices are typically integrated component assemblies which translate or convert microwave signals into lower (or intermediate) frequencies or higher frequency ranges in order to effect further signal processing in either the transmitter (stimulus generator) or receiver (response processor) portions of modern day communication and test & measurement systems.

RF/MW frequency translation devices are primarily available in two basic configurations: Up Converters and Down Converters. As its name implies, Up Converters are primarily utilized to transform RF/MW signals from a lower frequency spectra to a higher frequency range or band (i.e., L Band to C Band). Conversely, Down Converters alter RF/Microwave signals from a higher frequency to a more manageable Intermediate Frequency (IF) range where more readily available components can be employed for signal processing. Some variations of Frequency Translation Devices employ dual Up Converters and Down Converters whereby the devices can be utilized to translate transmitter (stimulus) or receiver (response) signals either up or down in frequency.

A linear device such as a filter will only affect the amplitude and phase of an input signal. Its primary purpose is to attenuate certain frequency bands while allowing others to pass with minimal loss – no signal frequencies are added to the device’s output frequency spectrum. FTDs, on the other hand, are non-linear devices by definition. That is, if a frequency appears at the output of a device that is not present at its input, it is said to have non-linear effects. A FTD (**Fig.1**) is designed to utilize its non-linear effects to shift one or more of its input signals by a fixed predetermined amount via a frequency mixing process employing either an internal or external Local Oscillator (LO). Except for frequency translation, FTDs are expected to behave linearly. Similar to filters and amplifiers, they exhibit gain or loss, a particular frequency response, and all the other characteristics of linear devices. They also exhibit many of the same undesired non-linear behaviors of amplifiers such as compression and

intermodulation distortion. RF/MW Frequency Translation Devices perform their frequency transformation functions by employing any number of Local Oscillator technologies when Up Converting (“mixing up”) or Down Converting (“mixing down”) the target signal in frequency. LO Technologies often employed in this regard include Frequency Synthesizers, Quartz Crystal Oscillators, and Yttrium Iron Garnet (YIG) Resonator Oscillators. Frequency Synthesizers typically employ a Phase Locked Loop (PLL) as the primary mechanism to generate the desired/target frequency, while Quartz Crystal Oscillators employ high-Q crystals that provide extremely accurate frequency control. In general, Quartz Crystal Oscillators are more accurate than Frequency Synthesizers; however state of the art Frequency Synthesizers are more flexible devices to design into a system employing FTDs when variable or programmable frequency selection/mixing is a design goal. Another FTD LO option is the use of YIG tuned Oscillators (YTOs). YTOs use highly polished YIG spheres as resonant devices with magnets to tune to their resonant frequencies to highly accurate values.

Figure 1. Fout proportional and at an offset frequency to Fin

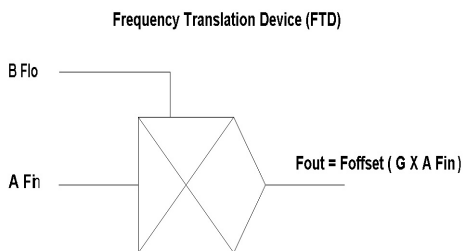

A number of RF/MW frequency translation related specifications must be considered when designing or procuring a Frequency Translation Device. Probably one of the most important specifications to consider, besides its electrical characteristics which will be discussed later in Section III of this paper, is form factor. An ever increasing emphasis on test equipment down sizing, interoperability, & mobility in the DOD test and measurement community has placed an increased focus on Synthetic Instrumentation and its implementation in modular technologies, such as VXI. Specifying

and designing a frequency translation capability into a VXI format provides a number of challenges (especially in the domain of Down Converters) to both the SI designer and user. Unless the design approach is modular in nature, the electrical specification and form factor needs of the customer may be at risk.

The ensuing paragraphs of this paper focus in on the Down Converter (DC) in the context of a Synthetic Instrument (SI) and provide an overview of critical parameters and a flexible architecture that should be considered when employing this class of Frequency Translation Device.

## DOWN CONVERTER IN THE CONTEXT OF A SYNTHETIC INSTRUMENT

The genesis of Modern Day instantiations of Synthetic Instruments (SI) find their roots in the communications revolution of the past decade and the emergence of a concept called “Software Defined Radios,” or SDRs. Simply defined, an SDR consists of a Digital Signal Processor or DSP, a Transmitter, a Receiver, and a transmission antenna. The transmitter and receiver convert digital data to and from modulated radio waves for wireless communication purposes. The DSP provides the radio functionality, via its software component, whereby application specific algorithms generate or process digitally represented signals for transmission or reception by the SDR.

The concept of Synthetic Instruments (**Fig.2**) leverages off of the SDR paradigm. SI is predicated on the concept that most stimulus and measurement functions can be implemented in software employing “Core” SI hardware & software components (Frequency Up/Down Converters, Digital to Analog Converters (DACs), Analog to Digital Converters (ADCs), DSP hardware/software) and supplemented, as required by the user’s envelope of test requirements, by Commercial off the shelf hardware (i.e., Power Supplies, fixturing, loads, etc.).

Figure 2. The Down Converter in a Synthetic Instrument Context

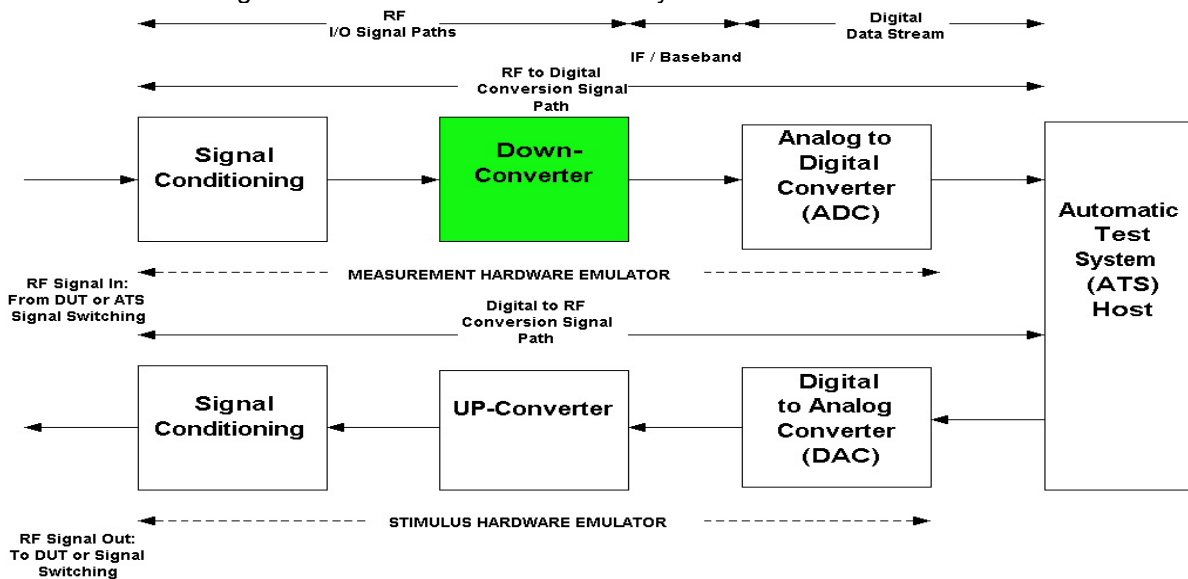

## DOWN CONVERTER CRITICAL PARAMETERS & TECHNOLOGIES

A number of Down Converter parameters must be specified and optimized over a broad array of SI user needs, some of the more critical ones are:

- RF/MW Input Specifications:
  - Frequency Range, VSWR (Impedance), Input Step Attenuator Range/Step Size, Instantaneous Dynamic Range, Minimum Signal Input Level/Sensitivity, 1 dB Compression Pt., Maximum Continuous Signal Input Level, Instantaneous BW, Input Filtering Requirements(pre-selection), Noise Fig., and Connector Type.
- Local Oscillator Input Specifications:
  - Frequency Range of the Local Oscillator (LO) Input, External or Internal Local Oscillator Tuning/Switching Speed (must be compatible with UUT test time requirements), Input Power Range (dBm), VSWR (Impedance), and Connector type
- Intermediate Frequency (IF) Output Specifications:
  - Frequency Range and Bandwidth (3dB BW), Conversion Gain/ Loss, IF Flatness, Noise Figure or Noise Floor (average displayed noise), IF Bandwidth Flexibility/Modularity, Intermediate

Frequency Output Level/Dynamic Range (must be compatible with digitizer technology to be utilized), Impedance, and Connector Type.

- I/O Signal Isolation (dB) Specifications:
  - LO to RF/MW
  - LO to IF
  - RF/MW to IF

In particular, the specification of a Down Converter's IF bandwidth is of critical importance. In some instances, such as capturing complex modulation formats, a wide IF bandwidth is required to faithfully acquire the information content in the baseband signal. In other applications such as AM or FM modulation, the frequency span of the signal(s) of interest are narrower and hence a narrower IF bandwidth can be utilized. In many ATS applications more than one Down-Converter instantiation may have to be utilized to satisfy the broad range of frequency spectra applications to be processed. Past experience and best practices in the RF/Microwave industry have taught us that there really is no such thing as a standard Down Converter: "One size does not fit all." All Down Converters are essentially married with other functional elements in a target system/application and have to complement and work in harmony with these elements. For this reason, application flexibility is a key feature that users should focus in on when designing in a Down Converter, or a "Family of Down Converters, "into their target

application. This “flexibility factor” becomes most important when working in an open architecture environment where one vendor is not providing all of the technology required, or where all of the technology required may not be available from one vendor. For example, each marriage of a down-converter reference design may require some changes to its baseline characteristics to maximize system performance. As mentioned previously, this may involve modifying IF frequencies and/or bandwidths, gain, output power, and video/detector output levels. Configuring a down converter for a particular application could quite often require mix and matching a block of circuits from a vendor’s design library in order to satisfy the requirements of a particular application. In addition, multiple Down Converter technologies often need to be employed in order to satisfy the broad-based needs often encountered in global ATS support programs. These technologies may include:

- Block Down-Conversion: Frequency translation from one band to the next.
- Tuned Down - Conversion: Employing a broadband Local Oscillator (i.e., Frequency Synthesizer) with a frequency resolution as low as 1-3Hz.
- Harmonic Mixing: Using a fixed Local Oscillator and a tunable YIG filter to sift out unwanted harmonics from the RF.
- Sampling: A special form of harmonic down conversion employed in instruments such as Oscilloscopes and Microwave Transition Analyzers.

## **A FLEXIBLE DOWN CONVERTER ARCHITECTURE**

A Down Converter’s functionality is often implemented by integrating a number of primary components such as an input attenuator, input filter/preselector, an RF Low Noise Amplifier, a Local Oscillator, mixers, one or more stages of an IF amplifier and associated filtering/amplification, and a video detector – where required. In essence, a Down Converter in most instances represents a minimal Spectrum Analyzer (**Fig.3**) front end, minus its back end display capabilities. As opposed to designing an integrated Spectrum Analyzer front end, the challenge in DC design in a VXI context is how to modularize its design in order that the unique test requirements of the user may be adapted and optimized from application to

application based on the user’s critical set of Down Converter specifications.

Once the determination of a critical set of Down Converter specifications pertinent to a target application is finalized by the user, the first step in the design process is the mapping of these specifications to specific Down Converter features and technologies for implementation. **Fig. 4** depicts an example of a state of the art Down Converter architecture/reference design employing a flexible mix of functional modules (Low Band Module, YIG Filter Preselector Module, Auxiliary IF Module, and Video Output Module) and technologies encompassing Tuned Down Conversion and Yttrium Iron Garnet (YIG) filtering. This flexible COTS reference design is often tailored /adapted in a modular fashion to address the unique needs of each custom application. A brief description of this flexible Down Converter architecture is provided in the ensuing paragraphs.

The RF Input section of the architecture employs a Step Attenuator Module, Switching Module, YIG Filter Preselector Module, and a Linear Amplifier (LNA) Module. The Step Attenuator Module is incorporated into the architecture in order to scale the RF/MW input signal level to the dynamic range of the Down Converter.

When multisignal environments are an integral part of a target application, the YIG tuned front end pre-selector module can be used to eliminate image frequencies and unwanted signal spectra; similar to the capability provided in a Spectrum Analyzer front end. The YIG preselector module incorporates a crystal magnetic insulator) which behaves as a bandpass filter at microwave frequencies; its center frequency is proportional to a magnetic field which is applied across the crystal via the use of electromagnets incorporated within the module. YIG technology employed in this module provides a number of benefits including burnout protection and unparallel frequency selectivity. YIG technology is an excellent current limiter and typically provides protection against high power signals of 30 watts or more. In terms of frequency selectivity, the YIG resonator can be tuned rather quickly by electrical means over a large frequency range. The YIG’s center frequency can be shifted by varying its input current which in turn changes the strength of the magnetic field applied to the YIG crystal.

Figure 3. Classical Spectrum Analyzer Architecture Front End: The Essential Components of a Down Converter

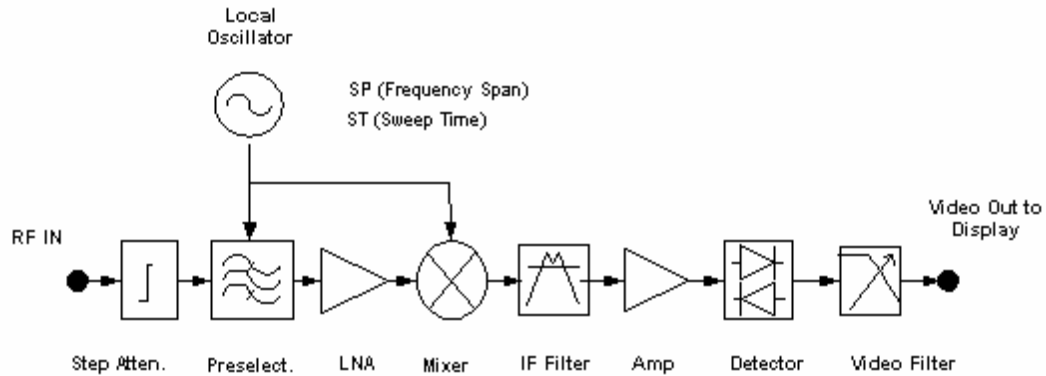
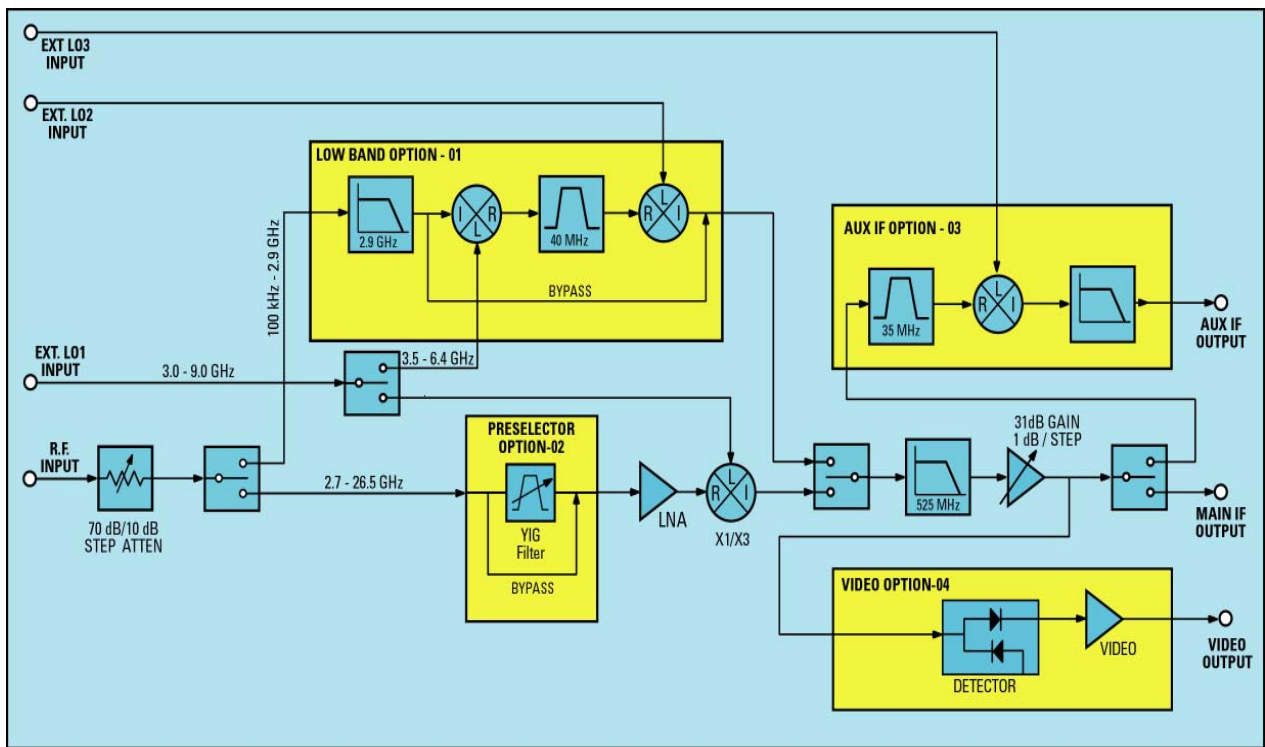

Figure 4. A Critical SI Technology: Flexible Down Converter Employing Multiple Technologies



For example, if you need to measure a very low level signal (-100 dBm) in the presence of a large signal (+ 10dBm) say in the vicinity of 50 MHz apart, YIG filtering is essential. Otherwise, the high level signal will overdrive the Down Converter's mixer input. If you increase the input attenuation of the step attenuator to prevent this event from occurring, then the lower level (target) signal of interest will also be attenuated. The YIG when properly tuned will filter out the larger signal and allow the mixer to be stimulated by the

smaller signal. In Fig.4, the YIG preselector filter and Linear Amplifier (LNA) modules provide filtering and signal amplification for signal spectra > 3 GHz at signal levels less than ~ -120 dBm. The facility to bypass the YIG filter where the application does not require it, in order to eliminate unnecessary signal attenuation, is also accommodated within the architecture.

By having the facility to employ externally tuned LOs, the architecture provides the user maximum

latitude in configuring an SI application, and provides application programming flexibility as well. The standard DC architectural configuration employs a single Local Oscillator (LO #1) and employs the classic X1/X3 LO input for harmonic heterodyne conversion to a 100 kHz- 525 MHz Main IF (user definable). Additional LO sources for Low – Band (100 kHz - 2.9 GHz) and Auxiliary IF low frequency outputs can also be accommodated by this flexible architecture.

A primary attribute of this flexible DC architecture is its ability to function with a broad array of digitizers that may be employed in an SI environment. A precision 1 dB variable IF step attenuation capability allows for correction of frequency dependent conversion loss variations. In addition to the Main IF and Auxiliary IF Outputs, the architecture provides a Video Output module which can be employed to provide video/level triggering, and AM/Pulse demodulation analysis.

The measurement accuracy of this flexible hardware architecture is enhanced and supported by five sets of frequency related correction curves (main path loss, step attenuator loss, YIG loss, residual IF loss, and IF filter shape loss) which can be embedded in the user's SI control software.

## SUMMARY/CONCLUSIONS

The Down Converter is a complex Frequency Translation Device which must be precisely specified and designed to satisfy the unique needs of the customer's application. In the context of a Synthetic Instrument, the Down Converter is a critical component and provides a window to the spectra of the analog world, which is subsequently digitized by an Analog to Digital Converter (ADC) and analyzed by Digital Signal Processing (DSP) software in the digital domain. A number of technologies (i.e., Harmonic Mixing, Tuned Down Conversion, and YIG Filtering) and associated components (i.e., YIG Filters, Mixers, Frequency Synthesizers (LOs)) can be utilized to synthesize a Down Converter's functionality. It is the authors opinion that a modular approach which can mix and match various technologies and components to best satisfy the needs of the user is the best approach and is predicated on previous lessons learned: **"One size does not fit all."**

## REFERENCES

- [1]. Myer, Robb, "Overcoming Mixer Measurement Challenges," Net Seminar: Agilent Technologies & CMP Media (Oct.10, 2002).
- [2]. Global Spec Product Finder, RF Frequency Converters, <http://www.globalspec.com>.
- [3]. Granieri, Mike, "Synthetic Instrumentation: An Emerging Technology (Part I)," RFDESIGN (Feb.2004), pp. 16-25
- [4]. Agilent Technologies, Application Note: "AN-150 Spectrum Analyzer Basics."
- [5]. Losee, Ferril, RF Systems, Components, and Circuits Handbook, Norwood, Ma. : Artech House, 1997, pp. 143-175
- [6]. Phase Matrix, Inc., Product Description: Phase Matrix 1313B Down Converter, <http://www.phasematrix.com>